



**ARCANO** (16+)

Teatro de Marionetas do Porto

## SYNOPSIS

### ARCANO

The unusual universe of Franz Kafka is explored in ARCANO with all its dark imagery, leading the audience to the recesses of the human mind. It is a fragmented performance, which through space, the actor, the marionette and the word, seeks a balance between reality and hallucination, organic and mechanical, metaphysics and the need to solve it.

“The animal pulls the whip out of its owner’s hands and whips itself, unaware that this is just a fantasy produced by a new knot in the belt.” Franz Kafka



# ARTISTIC FILE

## **ARCANO**

Staging and scenography  
**Rui Queiroz de Matos**

Texts  
**Rui Queiroz de Matos, based on Franz Kafka**

Marionettes and illustration  
**Júlio Vanzeler**

Costumes  
**Patrícia Valente**

Sound design  
**Luís Aly**

Lighting design  
**Filipe Azevedo**

Cast  
**Micaela Soares, Rui Queiroz de Matos e Vitor Gomes**

Production  
**Sofia Carvalho**

Graphic design and production assistance  
**Pedro Ramos**

Lighting and sound operation  
**Filipe Azevedo**

Construction technicians  
**João Pedro Trindade e José Simões**

Costumes making  
**Susana Sequeira**

Stage photography  
**Susana Neves**

Co-production  
**Teatro de Marionetas do Porto and Teatro Municipal do Porto**

Thanks  
**IEFP - CACE Cultural do Porto**

# TECHNICAL RIDER

## ARCANO

### Stage

9 m - Downstage (min.)

10 m - Depth (min.)

6,5 m - Height (min.)

**Cena negra** - 1 black backdrop, (see plan attached)

Black floor (linoleum or wood)

*Red linolium square with 4,8m (company equipment)*

### Lighting

Dimmers digitais - 76 circuits - Communication Protocol DMX 512

Lighting console grandMA 2 (*company equipment*)

Light stage bars (*see attached plant*)

Filters (*company equipment*)

#### **Spotlights:**

13x PC Strong 1Kw (*company equipment*)

6x PC 329 HF Robert Juliat 2Kw (*with barndoors and filter frames*)

18x PAR 64 1Kw (10x Cp61 | 8x Cp62) (*with filter frames*)

20x Profiles Robert Juliat 614X 1Kw 16º/35º (*with barndoors and filter frames*)

15x Profiles ETC Source Four Junior 23º/50º (*with barndoors and filter frames*) (*company equipment*)

3x Linelights with 480W (*with 8 bulbs of 60W*) (*company equipment*)

1x LED hose 12V with transformer (*company equipment*)

### Sound

2x Monitors on stage

PA system suitable for the space

Soundboard minimum 3 channels (*company equipment*)

1x Computer for sound operation (*company equipment*)

1x Microphone headset (*company equipment*)

### Backstage

3 individual dressing rooms or 1 collective

### Assembly

12 hours (3 shifts of 4 hours)

Disassembly and loading:

2 hours

## STAFF NEEDED

### ARCANO

- 2 assistants for loading and unloading
- lighting technician
- sound technician

## WORK PLAN

	SCENOGRAPHY	BLACK SCENE	LIGHTING	SOUND
1st SHIFT 4h	SETTING-UP	SETTING-UP	SETTING-UP	SETTING-UP
2nd SHIFT 4h		CHECKING	CHECKING	CHECKING AND PROGRAMMING
3rd SHIFT 4h			PROGRAMMING AND REHEARSAL	GENERAL REHEARSAL

## NOTES

- Before setting up, the stage and grid must be clean and without any equipment.

The performance lasts for **60 minutes**

Language: **integrally in English**

Age rate: **16+**

**All promotional material for the performance must include the following:**

Company sponsored by República Portuguesa/Ministério da Cultura and DGArtes (with logos)

Co-production Teatro de Marionetas do Porto and Teatro Municipal do Porto

# LIGHTING PLANT

## ARCANO

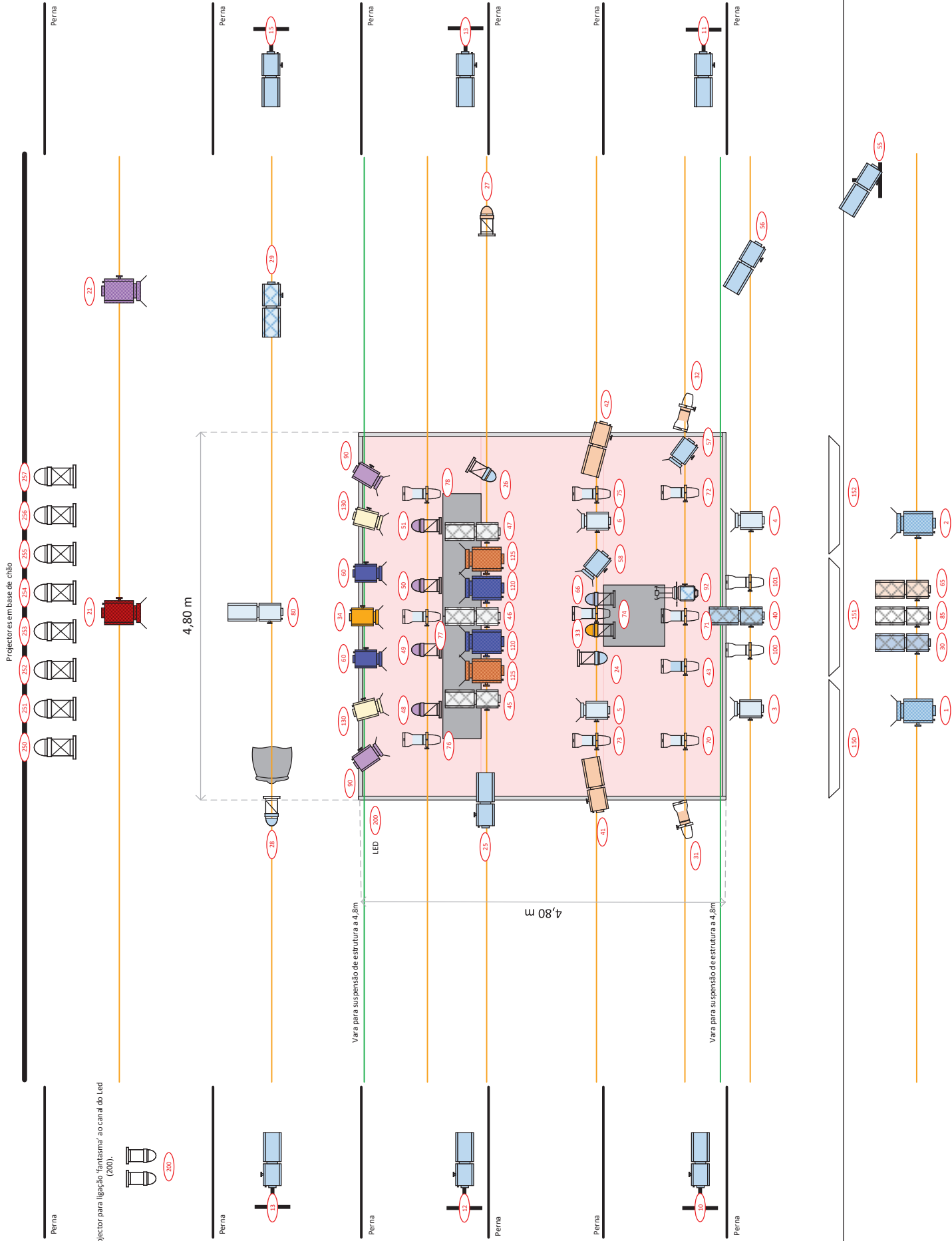

STAGE PHOTOGRAPHY  
ARCANO

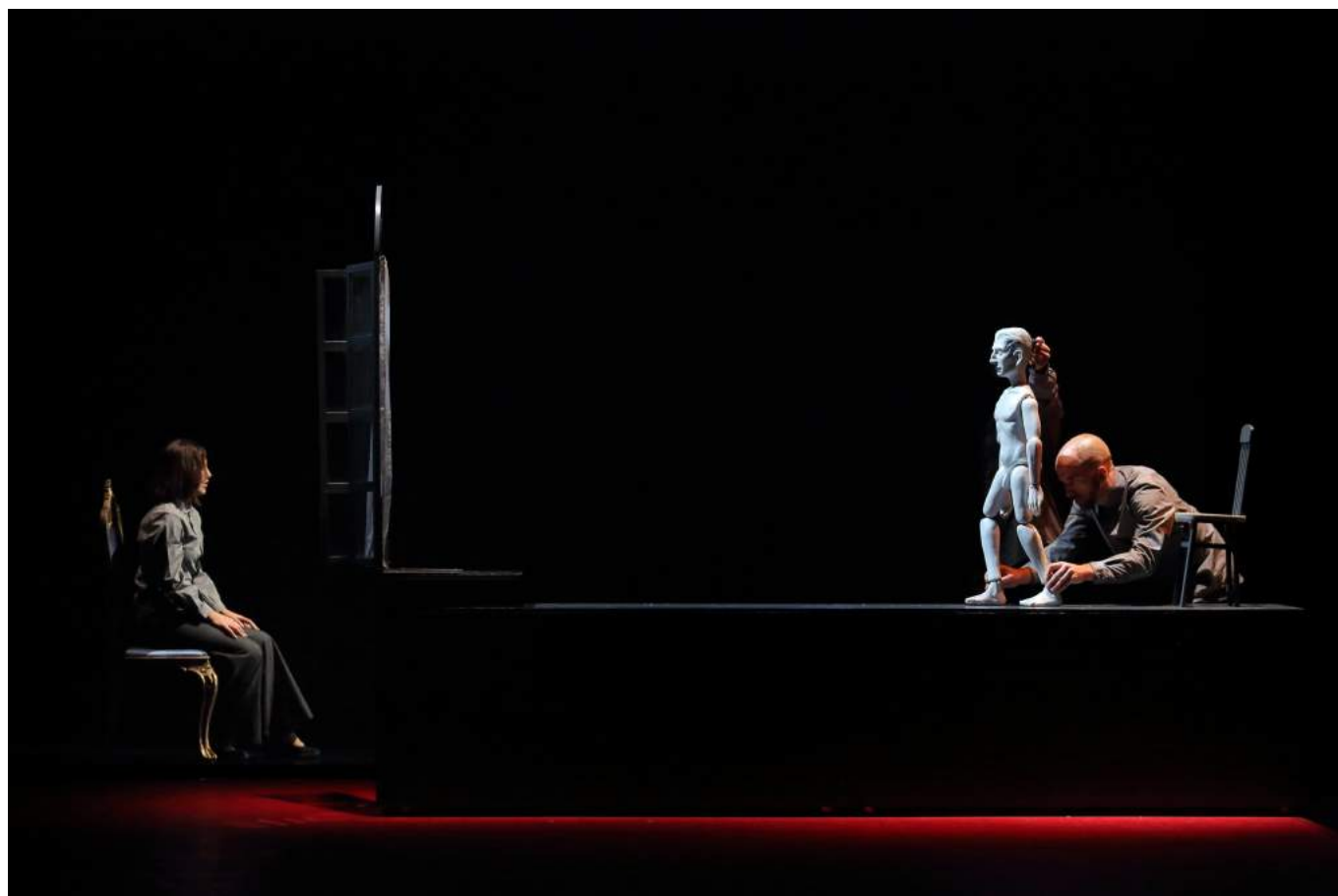



STAGE PHOTOGRAPHY  
ARCANO





STAGE PHOTOGRAPHY  
ARCANO



STAGE PHOTOGRAPHY  
ARCANO

