

GOVERNO DE PORTUGAL

SECRETÁRIO DE ESTADO DA CULTURA

dg DIREÇÃO GERAL DO TEATRO

SYNOPSIS

PELOS CABELOS

Inspired by the illustrations of João Vaz de Carvalho named Pelos Cabelos (Hair Hairs), Teatro de Marionetas do Porto has created a performance inhabited by unusual characters with an absent-minded and hallucinated gaze. Humor and the absurd merge in this performance, providing us with yet another experience where marionettes abound. In Pelos Cabelos (Hair Hairs), performers and marionettes are inhabitants of a place located somewhere; an "Out There", a distant, almost extraterrestrial place.

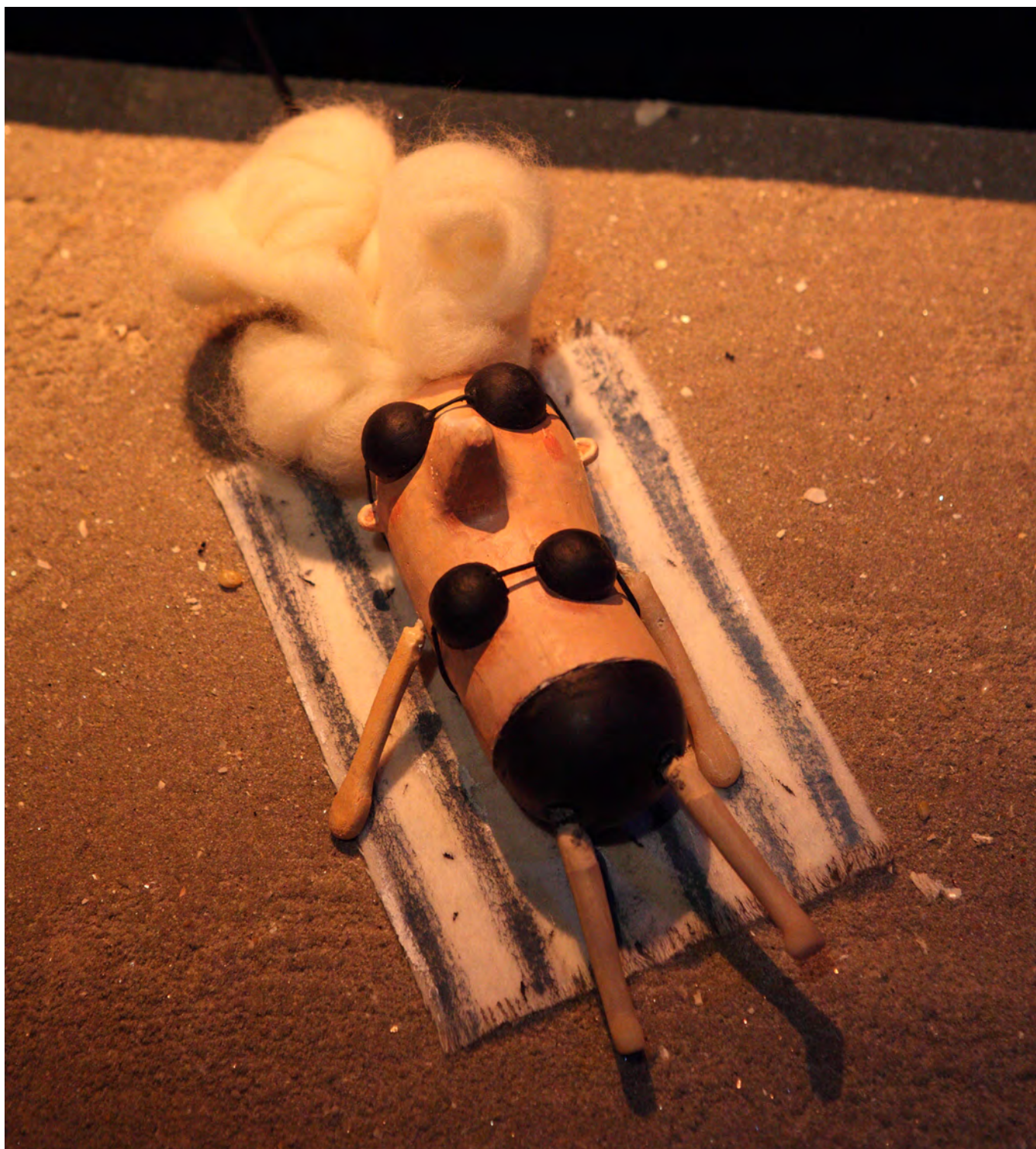

ARTISTIC INFORMATION

PELOS CABELOS

Staging and scenography

Isabel Barros

Texts

Edgard Fernandes

Isabel Barros

Rui Queiroz de Matos

Marionettes

Sandra Neves (from the illustrations of João Vaz de Carvalho)

Music and Animation

Coletivo HUSMA (João Apolinário, Nuno Cortez and Pedro Cardoso)

Lighting design

Alexandre Vieira

Cast

Rui Queiroz de Matos

Vitor Gomes

Production

Sofia Carvalho

Lighting and sound operation

Filipe Azevedo

Marionette construction

Sandra Nevez (coordination)

Nuno Guedes

Teresa Dantas

Rita Silva (trainee)

Scenographic construction

Américo Castanheira, Tudo-Faço

Photography

Susana Neves

Acknowledgements

Ensemble, Escovaria de Belomonte

TECHNICAL RIDER

PELOS CABELOS

STAGE

- Minimum : 5,5m - downstage / 5,5m - depth / 3,5m - height

CENA NEGRA

- Typical italian scene
(see plan attached)
- Black floor (linoleum or wood)

LIGHTING

- Digital dimmers - 34 circuits - Communication Protocol DMX512
- Lighting console grandMA 2 Ultra Light (company equipment)
- Light stage bars (see plan attached)

- Structures:

2 towers 1.50m high (see plan attached)

- Spotlights:

(Ver planta de luz)

116x Fresnel/PC 1000w with barndoors and filter frames

13x Profile spotlights 1000w 23/50 with filter frames

5x Profile spotlights 1000w 14/35 with filter frames

2x iris for profile spotlights

- Filters:

Company equipment

SOM

1 Monitor on stage

PA system suitable for the space

Soundboard minimum 2 channels (company equipment)

VÍDEO

1 Screen Led 40" HD (company equipment)

Laptop computer (company equipment)

Connection stage/video control by VGA 50m (company equipment)

BACKSTAGE

- 3 single dressing-rooms or 1 multiple dressing-room

SETTING-UP TIME

- 10 hours

Disassembling and upload:

- 2h00

SUPPORT STAFF NEEDED

- 2 assistants for loading and unloading
- 2 lighting technicians
- Sound technician
- Video technician
- Stage technician

WORK PLAN

	SCENOGRAPHY	BLACK SCENE	LIGHTING	SOUND
1ST SHIFT 4h	SETTING-UP	SETTING-UP	SETTING-UP	SETTING-UP
2ND SHIFT 4h		CHECKING	CHECKING AND PROGRAMMING	CHECKING AND TESTS
3RD SHIFT 2h			GENERAL REHEARSAL	GENERAL REHEARSAL

NOTE

- Before setting up, the stage and grid must be clean and without any equipment.

The performance lasts for **40 minutes**

Age rate: **3+**

All promotional material for the performance must include the following:

Company sponsored by Governo de Portugal/Secretário de Estado da Cultura and DGArtes (with logos).

LIGHTING PLAN

PELOS CABELOS

Fundo Negro

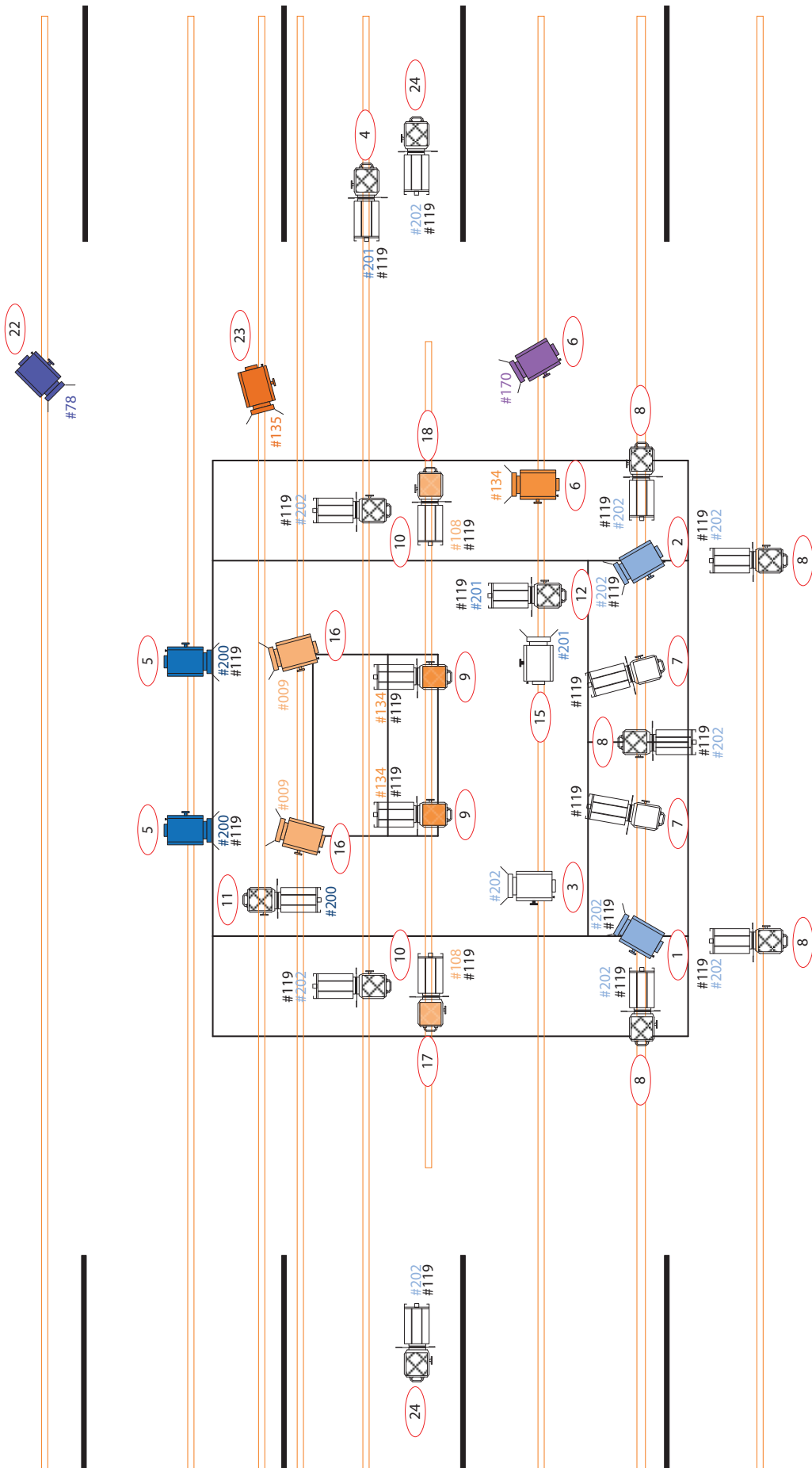

A PLACE OF WIRES AND FINGERS

João Vaz de Carvalho illustrated and TMP leads to the scene. In Pelos Cabelos (Hair Hairs), there are unusual characters with an absent-minded and hallucinated gaze. Actors and wires give movement and soul to the marionettes in a performance where humour and the absurd combine for a magical experience with puppets. The show is designed for kids, but the adults will want to watch it. It's the only way to get to know a place located somewhere, a distant "Out There", a world apart, with stories of growing hairs, without ever being cut, that create ties and numberless connections.

Susana Silva Oliveira (Visão – Sete Norte – 21.11.2013)

"PELOS CABELOS" IN LIVING DOLLS PREMIERES TODAY... OUT THERE

The performance by Teatro de Marionetas do Porto originates in the illustrations of João Vaz de Carvalho. Out There is where everything usually happens, except combing. Out There, there are dogs and rockets, and we don't know if there will be trains. And who are the inhabitants? Who lives Out There? So many questions, only one solution: go to the small auditorium of Belomonte Street and see the play "Pelos Cabelos". It's the new production of Teatro de Marionetas do Porto and its premiere is today at 11 am.

We know that the Brush Couple live there, the Pillar Woman, Ms. Rain, I Love You the dog, Mr. Lint or Mr. Moustache. These characters were born in the series of illustrations called "Pelos Cabelos" (Hair Hairs) by João Vaz de Carvalho, but now they have names and were adapted for theater with texts by Isabel Barros and also by the two actors, Edgard Fernandes and Rui Queiroz de Matos.

It is the second time that Teatro de Marionetas do Porto works with the art of this illustrator, but with a different approach. In "Cinderella," the 2009 performance, the illustrations were born after the story, while the illustrations of "Pelos Cabelos" came before the text. Some of them were exhibited in the company museum, open since February. But let's go back Out There. Over 45 minutes, the audience will come across a story without a thread, in a space that is nothing. Or it could be anything: a beach, a desert, a field, a village and who knows what else. Isabel Barros, responsible for staging and scenography, justifies this: "The images of João Vaz de Carvalho always suggested that they would land on nothingness."

Therefore, space is not defined, "it's a place without limits and borders", she says. It can also be "the place of dreams", says the company's director, stressing that the characters live in a sort of loneliness, yet "a positive and full loneliness". The few words that we hear throughout the performance are left floating in the air, such as the hairy clouds that keep appearing among the unusual and pleasantly crude characters.

Isabel Peixoto in Jornal de Notícias – 23.11.2013

STAGE PHOTOGRAPHY
PELOS CABELOS



STAGE PHOTOGRAPHY
PELOS CABELOS

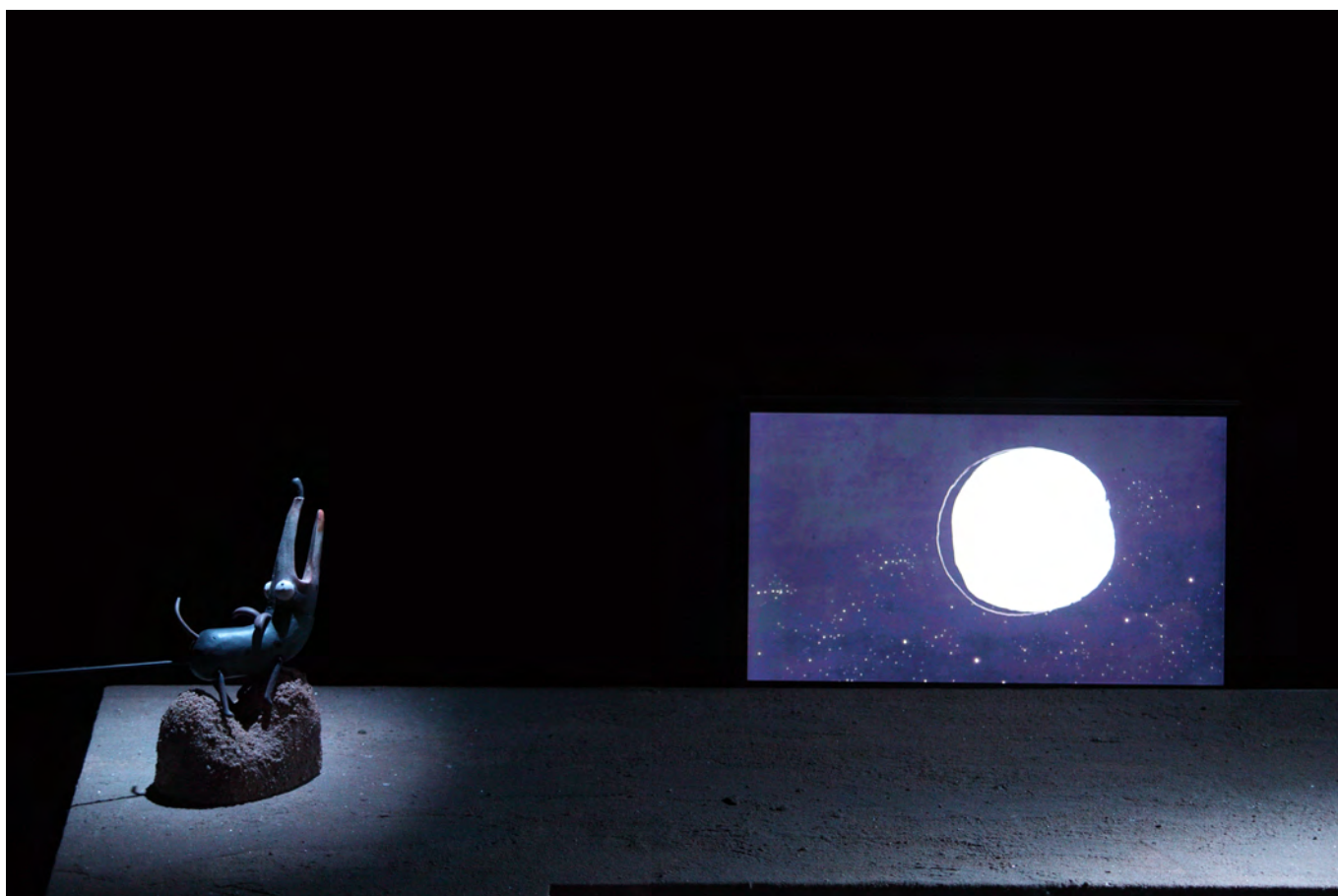

STAGE PHOTOGRAPHY
PELOS CABELOS

